

Interface

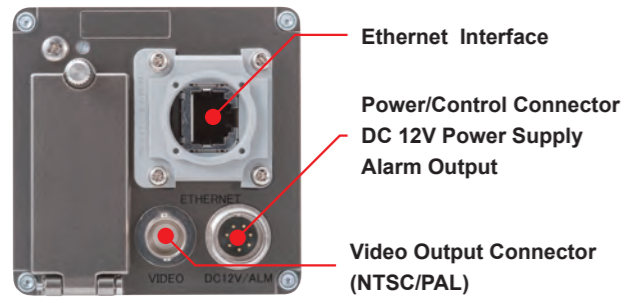

Pin Assignment of Power / Alarm Contact Connector (Round Connector Tajimi R04-R8M)

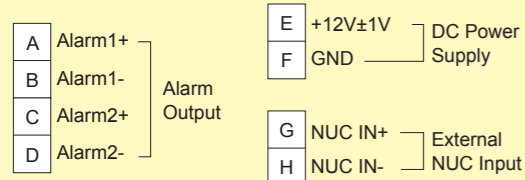

Measuring Distance and Field of View

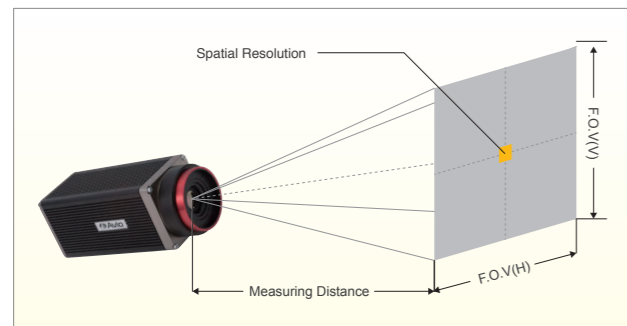

	Measuring Distance (m)	Field of View(H) (m)	Field of View(V) (m)	Minimum Detectable size (mm)
TS610/TS610-D 37.5°(H)×28.1°(V)	10	6.4	4.8	10
TS620/TS620-D 71.2°(H)×53.4°(V)	10	14.1	10.6	22
TS630/TS630-D 90.2°(H)×67.7°(V)	10	19.8	14.9	31

*Typical data

Specification

TS600 series

Type	TS610	TS610-D	TS620	TS620-D	TS630	TS630-D
Frame Rate	30Hz	7.5Hz	30Hz	7.5Hz	30Hz	7.5Hz
Field of View	37.5° × 28.1°		71.2° × 53.4°		90.2° × 67.7°	
Spatial Resolution	1.0mrad		2.2mrad		3.1mrad	

Specification

Basic Performance	Infrared Detector	UFPA(Microbolometer)
	Spectral Range	8 to 14um
	Measuring Range	-40°C to 1500°C
	Sensitivity(NETD)	0.03°C at 25°C(with S/N improvement)
Image Display	Accuracy	±2°C or ±2%(Range1,2)
	Detector Pixels	640(H)×480(V) pixels
	Focus	Pan-focus
Measuring Function	Auto Function	Auto Scale
	Color Palettes	7 Palettes(Rainbow,Brightness,Hot-white,Hot-black,etc)
	Image Quality Improvement	Denoising,Averaging(OFF / Low / Middle / High, with ghost rejection),Edge enhancement
	Point Temperature	10 Movable Points, Temperature Tracking,MAX/MIN ×1 each,Delta T
Interface	Temperature Display in Assigned Area	5 Boxes
	Line Profile	Horizontal,Vertical,Horizontal & Vertical
	Alarm Function	Alarm Display,Color Alarm,Alarm Signal Output 32 Arbitrary shape areas(by using Remote Program)
	Temperature Correction	Emissivity,Multi-point Emissivity, Environmental / Background,Distance,NUC
Other	Ethernet	100/10BASE-T (RJ-45)
	Protocol	Modbus, ONVIF, TS Protocol
	Video output	NTSC or PAL (BNC)
	Alarm Output	Non-voltage contact
	External NUC Input	1ch
	Operating Temperature & Humidity	-15°C to 50°C, 90%RH (non-condensing)
	Storage Temperature & Humidity	-40°C to 70°C, 90%RH (non-condensing)
	AC Power	DC 12V ±1V
	Power Consumption	8W(Typ)
	Dimensions	Approx. 68mm(H)×68mm(W)×175mm(D)
	Weight	Approx. 800g
	Vibration / Shock	19.6m/s ² (2G), 147m/s ² (15G)
	Dust / Splash Proof	Protection class IP54 equivalent
	Standard attachment	CD-ROM(Manual,Remote Program,NS9500LT,SDK)

NEW

Fixed Mount Type Thermal Imaging Camera

InfReC
InfraRed Camera

High Performance, High Image Quality for Network Solutions

InfReC TS600series

Various solutions for monitoring/ surveillance systems

Suitable design for contributing to various applications, monitoring process control or surveillance with adoption of general purpose protocol.

High Sensitivity

High Accuracy

High Temperature Range



• Listed specifications, appearance and design are subject to change without notice. • Company and commodity names are trade names or registered trade marks of each company. • NIPPON AVIONICS Co., Ltd. will not be responsible for any damage of infrared detectors due to incoming strong light (e.g. laser) through lens(es). • This product is subject to Japanese Export Control Law. Depending on its destination, prior assessment and authorization may be required. When exporting from country of initial purchase destination, please be sure to follow that country's export regulations as it may require an export permit beforehand.

NIPPON AVIONICS CO.,LTD.

Thermal Imaging Division

1-5, Nishi-Gotanda 8-chome, Shinagawa-ku,
Tokyo 141-0031 Japan

Phone : +81-3-5436-1614

Fax : +81-3-5436-1395

E-mail : product-irc-e@ml.avio.co.jp

<http://www.avio.co.jp/english/>



WARNINGS & CAUTIONS

- Before using this product, please carefully read the provided Operation Manual "WARNINGS" & "CAUTIONS" section to ensure proper operation.
- Please do not place the product in high temperature, high humidity or high inert gas environments.

Distributor:



NIPPON AVIONICS CO.,LTD.

An NEC Group Company

High Quality, High Resolution, Excellent Basic Performance

Latest VGA sensor technology for high image quality

·New sensor provides both high sensitivity and high resolution (640 ×480 pixels) with clear and high thermal image quality.

Highly accurate temperature measurement (± 2°C/2%)

·This meets market needs for highly accurate temperature sensing, such as in process monitoring or fire prevention monitoring.

Temperature range up to 1500°C

·Enables market needs of such as monitoring the temperature of die casting molds, monitoring the temperature of furnace materials and steel mills and plants, and measuring the temperature of metal or glass products, etc.

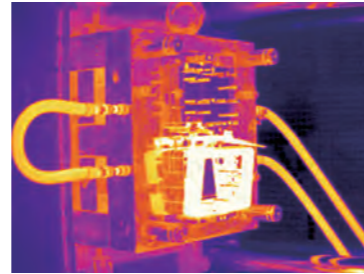

Die Cast Mold

Adoption of Generally used Protocol

Adoption of generally used Modbus TCP for Distributed Control System(DCS)

·Cameras can be added on to existing control systems by connecting to Modbus-compatible devices of DCS via Ethernet.

Network example of Distributed Control System (DCS)

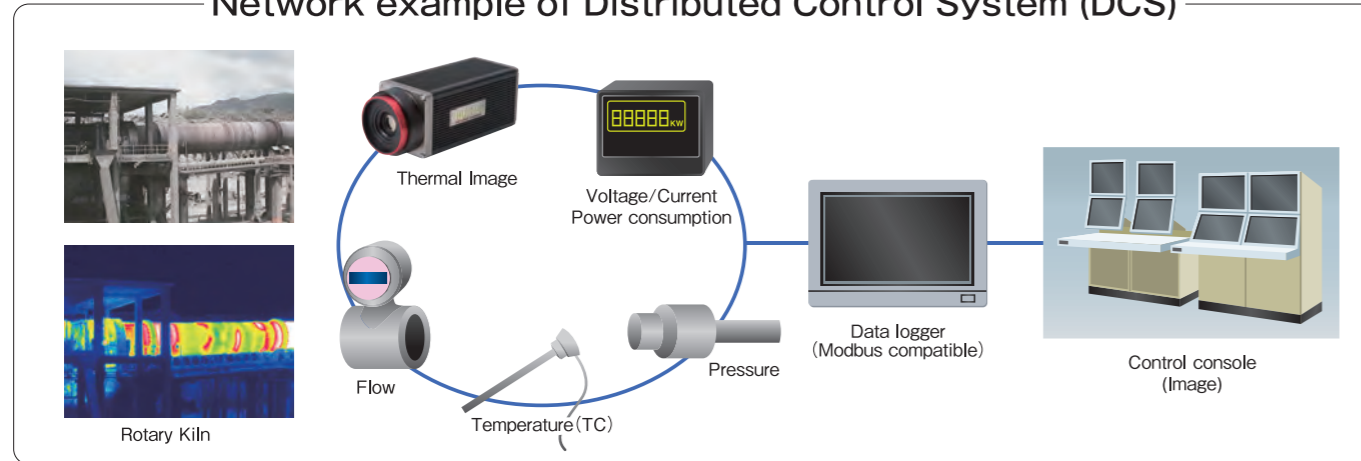

ONVIF protocol generally used in video surveillance

·Support for the ONVIF protocol generally used in video surveillance enables these cameras to be added on to existing camera network systems.



Security

Enhancement of alarm function on camera itself

·Divided into as many as 32 areas using straight, polygon and curved lines.
·Masking unnecessary area.

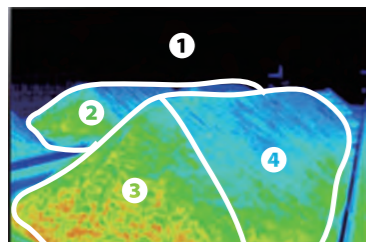

·Avoid No Monitoring Time from communication error, by 2 alarm systems both by camera and PC arrangement.



System Construction examples

Temperature monitoring of Die Cast/Molds

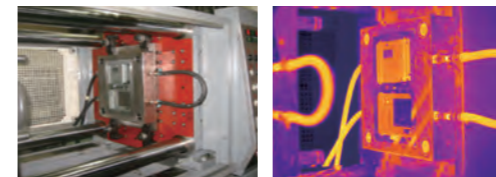
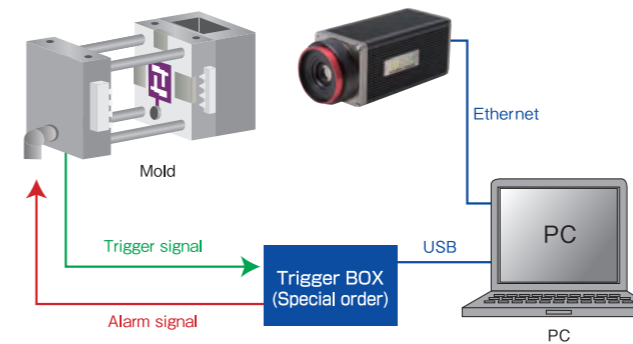

Temperature Monitoring of Ladle for melting steel

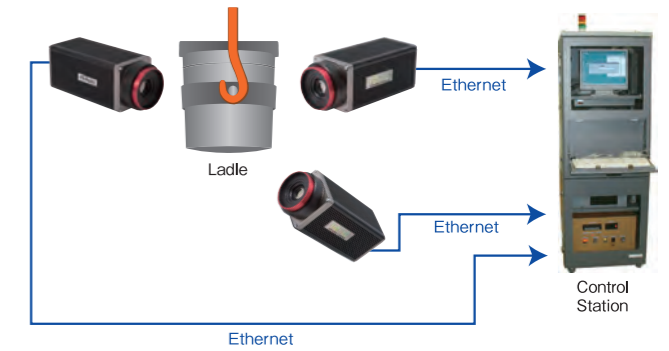

Fire Monitoring of Refuse Bunker

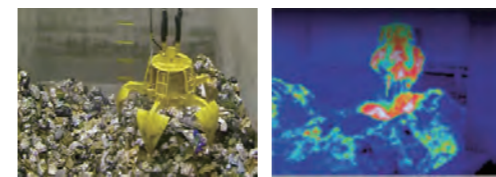
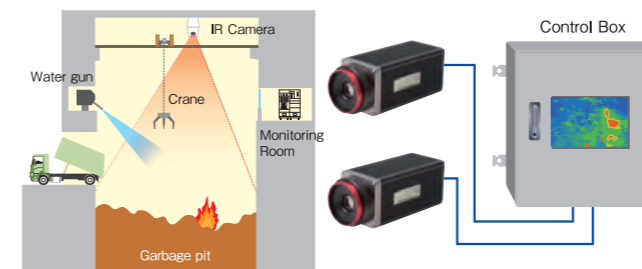

Fire Monitoring of Coal Conveyor

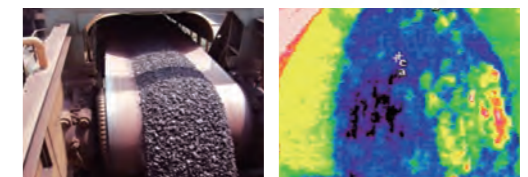
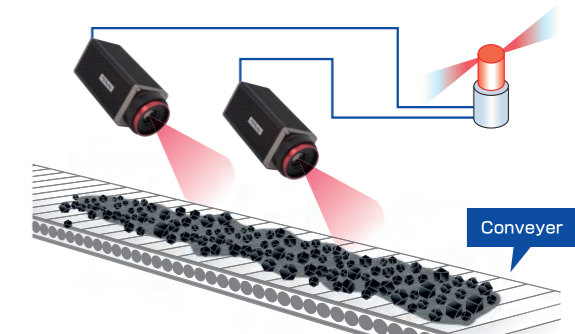

Others

SDK for programming the camera is standard equipped.

·Software development kit (SDK) is provided as a standard accessory so that system integrators or customers can write their own programs.

Enables direct camera setting by Remote controller, not via network.(Option)

·Simple and efficient camera setting at the adjustment of camera installation or at the time of maintenance.

High flexibility of support by special order basis

·Variety of customization possible as a special order on Lens, Housing, control panel, etc.

